



SUMITOMO

CARBIDE - CBN - DIAMOND

WGX

45° Face Mill



**Excellent
surface finish!
Eliminate
burrs!**



High Performance Milling Systems

WGX 45° Face Mill Milling Cutter for facemilling applications of Steel and Cast Iron



for facemilling applications



Features & Benefits

Stable Machining

Special chipbreaker designed for WGX Type ensures low cutting resistance

High Quality

Improved run-out precision and unique wiper edge shape ensure excellent surface finish quality
Optimized chamfer shape reduces burrs and edge chipping

Long Tool Life

Features high-precision technology that reduces insert run-out variation and a new coating to provide stable and long tool life

- New Super ZX, Super FF and DLC coated grades available
- Available in Standard, Fine Pitch and Extra-Fine Pitch cutters

Insert Shape Characteristics

Unique wiper edge shape for improved surface roughness

General Purpose G Type Chipbreaker

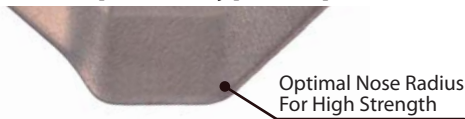

Low-Burr Design FG Type Chipbreaker

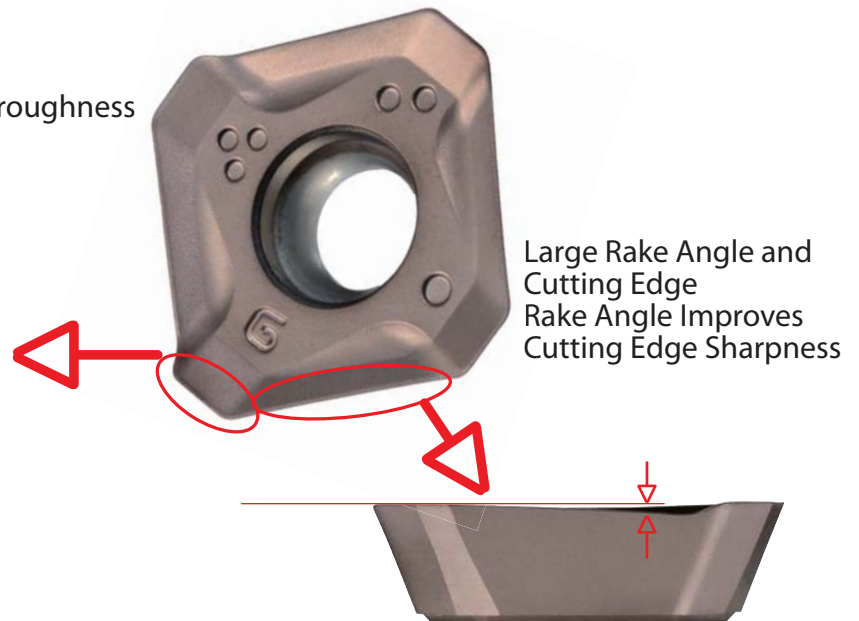
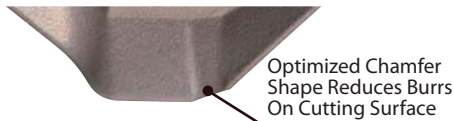

Cutting Resistance Comparison

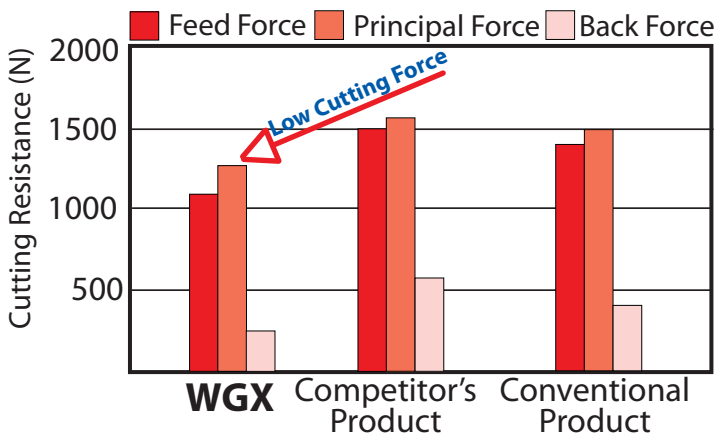

Finishing Surface Roughness Comparison

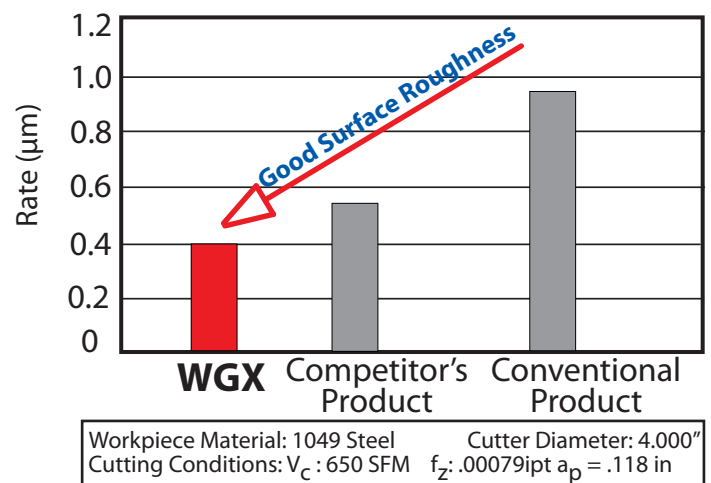

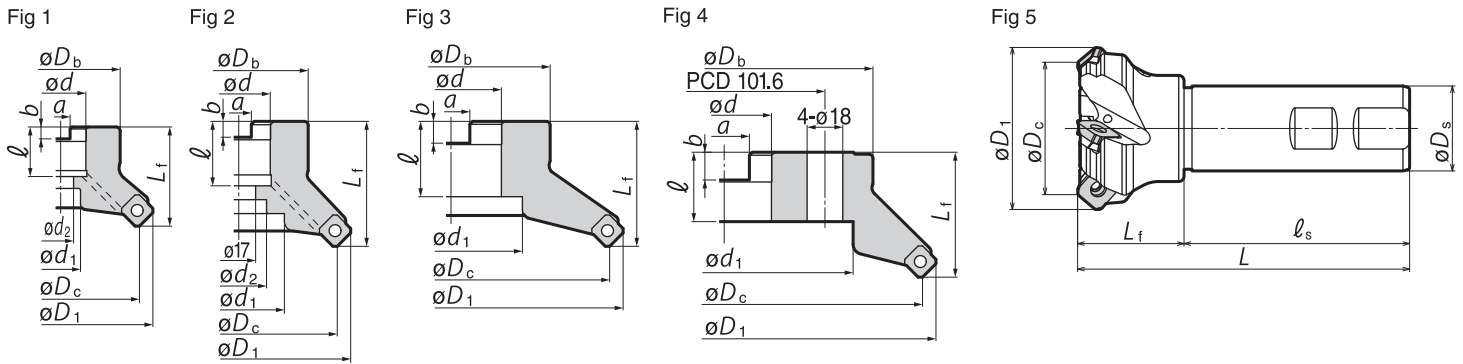

WGX Cutter Bodies-Coarse Pitch-INCH												
Catalog No.	ϕD_c	ϕD_1	ϕD_b	Lf	ϕD	ϕD_1	a	b	ℓ	Teeth	Weight (lbs)	Fig.
WGX42000R	2.000	2.461	1.500	1.750	0.750	0.609	0.312	0.190	0.750	3	.9	1
WGX42500R	2.500	3.008	1.750	1.750	1.000	0.797	0.375	0.220	0.750	4	1.3	1
WGX43000R	3.000	3.504	2.250	1.750	1.000	0.787	0.375	0.220	0.750	4	2.2	1
WGX44000R	4.000	4.500	2.870	2.000	1.250	1.000	0.500	0.280	0.750	5	3.5	2
WGX45000R	5.000	5.496	3.750	2.500	1.500	2.000	0.625	0.380	1.000	6	7.2	1
WGX46000R	6.000	6.496	4.380	2.500	1.500	2.000	0.625	0.380	1.060	7	9.5	3
WGX48000R	8.000	8.496	5.906	2.500	2.500	5.118	1.000	0.560	1.594	8	15.6	4
WGX410000R	10.000	10.492	7.480	2.756	2.500	6.299	1.000	0.531	1.575	10	23.5	4

WGX Cutter Bodies-Coarse Pitch-INCH												
Catalog No.	ϕD_c	ϕD_1	ϕD_b	Lf	ϕD	ϕD_1	a	b	ℓ	Teeth	Weight (lbs)	Fig.
WGXM42000R	2.000	2.461	1.500	1.750	0.750	0.609	0.312	0.190	0.750	4	.9	1
WGXM42500R	2.500	3.008	1.750	1.750	1.000	0.797	0.375	0.220	0.750	5	1.9	1
WGXM43000R	3.000	3.504	2.250	1.750	1.000	0.787	0.375	0.220	0.750	6	3.1	1
WGXM44000R	4.000	4.500	2.870	2.000	1.250	1.000	0.500	0.280	0.750	7	4.8	2
WGXM45000R	5.000	5.496	3.750	2.500	1.500	2.000	0.625	0.380	1.000	8	7.2	1
WGXM46000R	6.000	6.496	4.380	2.500	1.500	2.000	0.625	0.380	1.060	10	9.5	3
WGXM48000R	8.000	8.496	5.906	2.500	2.500	5.118	1.000	0.560	1.594	12	15.6	4

WGX Cutter Bodies-Coarse Pitch-INCH												
Catalog No.	ϕD_c	ϕD_1	ϕD_b	Lf	ϕD	ϕD_1	a	b	ℓ	Teeth	Weight (lbs)	Fig.
WGXF42000R	2.000	2.461	1.500	1.750	0.750	0.609	0.312	0.190	0.750	5	.9	1
WGXF42500R	2.500	3.008	1.750	1.750	1.000	0.797	0.375	0.220	0.750	6	1.5	1
WGXF43000R	3.000	3.504	2.250	1.750	1.000	0.787	0.375	0.220	0.750	8	3.1	1
WGXF44000R	4.000	4.500	2.870	2.000	1.250	1.000	0.500	0.280	0.750	10	4.7	2
WGXF45000R	5.000	5.496	3.750	2.500	1.500	2.000	0.625	0.380	1.000	12	8.2	1
WGXF46000R	6.000	6.496	4.380	2.500	1.500	2.000	0.625	0.380	1.060	16	10.5	3
WGXF48000R	8.000	8.496	5.906	2.500	2.500	5.118	1.000	0.560	1.594	20	15.2	4

Cutter diameters 6.000" and above do not have coolant holes

WGX Cutter Bodies - Shank - INCH									
Catalog No.	ϕD_c	ϕD_1	ϕD_b	Lf	ℓ_s	L	Teeth	Fig.	
WGX42000EW	2.000	2.461	1.250	1.591	2.379	3.970	4	5	
WGX42500EW	2.500	3.008	1.250	1.591	2.379	3.970	5	5	

Identification Details - Shell (Inch)

WGX F 4 2000 R

1 Cutter Series 2 M : Fine Pitched
F : Extra-Fine Pitched 3 Insert Series 4 Diameter (2.000") 5 Endmill Type

Identification Details - Shank (Inch)

WGX 4 2000 EW

1 Cutter Series 2 Insert Series 3 Diameter (2.000") 4 Endmill Type

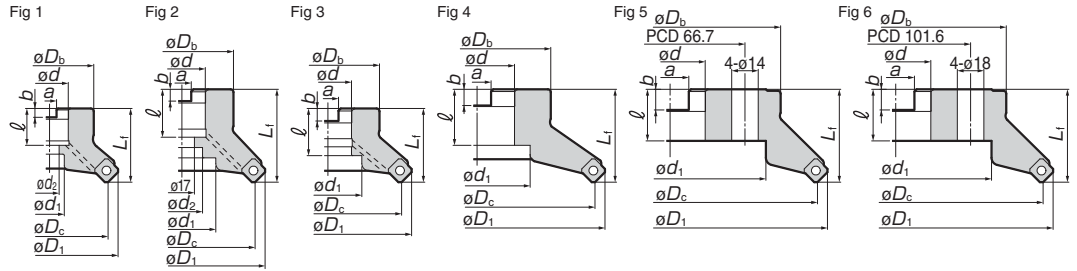

Body (Standard Pitch) - Metric

Cat. No.	Stock	Dimensions (mm)										No. of Teeth	Weight (kg)	Fig.
		ϕD_c	ϕD_1	ϕD_b	L_f	ϕd	a	b	ℓ	ϕd_1	ϕd_2			
WGX 13040RS	★	40	52	32	40	16	8.4	5.6	18	14	9	3	0.3	1
13050RS	★	50	62	40	40	22	10.4	6.3	20	18	11	3	0.4	1
13063RS	★	63	76	50	40	22	10.4	6.3	20	18	11	4	0.6	1
WGX 13080R	★	80	93	60	50	25.4	9.5	6	25	20	13	4	1.2	1
13100R	★	100	113	70	63	31.75	12.7	8	32.5	46	28	5	2.3	2
13125R	★	125	138	80	63	38.1	15.9	10	35.5	55	30	6	2.9	1
13160R	★	160	173	100	63	50.8	19	11	38	72	-	7	4.5	4
13200R	★	200	213	150	63	47.625	25.4	14	35	130	-	8	7.1	6
13250R	★	250	263	190	63	47.625	25.4	14	35	150	-	10	11.2	6

Body (Fine Pitch) - Metric

Cat. No.	Stock	Dimensions										No. of Teeth	Weight (kg)	Fig.
		ϕD_c	ϕD_1	ϕD_b	L_f	ϕd	a	b	ℓ	ϕd_1	ϕd_1			
WGXM 13050RS	★	50	62	40	40	22	10.4	6.3	20	18	11	4	0.4	1
13063RS	★	63	77	50	40	22	10.4	6.3	20	18	11	5	0.6	1
WGXM 13080R	★	80	94	60	50	25.4	9.5	6	25	20	13	6	1.1	1
13100R	★	100	114	70	63	31.75	12.7	8	32.5	46	28	7	2.2	2
13125R	★	125	139	80	63	38.1	15.9	10	35.5	55	30	8	2.9	1
13160R	★	160	174	100	63	50.8	19	11	38	72	-	10	4.5	4
13200R	★	200	214	150	63	47.625	25.4	14	35	130	-	12	7.0	6
13250R	★	250	264	190	63	47.625	25.4	14	35	150	-	14	11.1	6

Body (Fine Pitch) - Metric

Cat. No.	Stock	Dimensions										No. of Teeth	Weight (kg)	Fig.
		ϕD_c	ϕD_1	ϕD_b	L_f	ϕd	a	b	ℓ	ϕd_1	ϕd_2			
WGXF 13050RS	★	50	62	40	40	22	10.4	6.3	20	18	11	5	0.4	1
13063RS	★	63	77	50	40	22	10.4	6.3	20	18	11	6	0.6	1
WGXF 13080R	★	80	94	60	50	25.4	9.5	6	25	20	13	8	1.1	1
13100R	★	100	114	70	63	31.75	12.7	8	32.5	46	28	10	2.1	2
13125R	★	125	139	80	63	38.1	15.9	10	35.5	55	30	12	2.8	1
13160R	★	160	174	100	63	50.8	19	11	38	72	-	16	4.5	4
13200R	★	200	214	150	63	47.625	25.4	14	35	130	-	20	6.9	6
13250R	★	250	264	190	63	47.625	25.4	14	35	150	-	24	11.0	6

★: Worldwide Warehouse Item

Sizes $\phi 160$ mm or above do not have coolant holes

Identification Details:

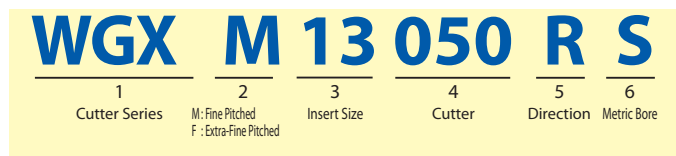

Body (Shank Type)

Cat. No.	Stock	Dimensions (mm)						No. of Teeth
		ϕD_c	ϕD_1	ϕD_s	L_f	ℓ_s	L	
WGX 13032EW	★	32	44	32	40	85	125	3
13040EW	★	40	52	32	40	85	125	3
13050EW	★	50	62	32	40	85	125	4
13063EW	★	63	76	32	40	85	125	5

★: Worldwide Warehouse Item

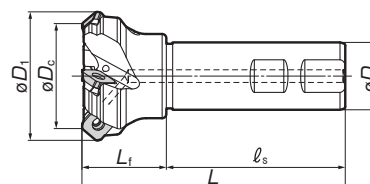

Inserts	P	K	M	N	Dimensions								
	ACP100	ACP200	ACP300	ACK200	ACK300	ACM200	ACM300	DL1000	H1	IC	Thickness	Facet Width	
SEMT13T3AGSR-L	●	●	●	●	●	●	●				0.528	0.156	0.0787
SEMT13T3AGSR-G	●	●	●	●	●	●	●						
SEMT13T3AGSR-H	●	●	●	●	●	●	●						
SEMT13T3AGSR-FG	●	●	●	●	●	●	●						
SEET13T3AGSR-L	●	●	●	●	●	●	●						
SEET13T3AGSR-G	●	●	●	●	●	●	●						
SEET13T3AGFR-L								●	●				

Parts	Applicable Cutters	Seat	Seat Screw	Insert Screw	Spanner (For Insert)	Recommended Tightening Torque Inch / LBs	Spanner (For Seat)
WGX cutters except for model below	WGC513R	BW0507F	BFTX03512IP	TRDR15IP	25	LH035	
WGX13032EW	—	—	BFTX03512IP	TRDR15IP	25	—	

Recommended Cutting Conditions					
ISO	Work Material	Hardness	Cutting Speed v_c (SFM) Min. - Optimum - Max.	Feed Rate f_z (ipt) Min. - Optimum - Max.	Grades
P	General Steel	180~280HB	490-650-825	0.004-0.008-0.0118	ACP
	Soft Steel	≤180HB	600-870-1,150	0.004-0.0098-.01575	ACP
	Die Steel	200~300HB	325-500-650	0.006-0.008-0.0098	ACP
M	Stainless Steel	—	525-675-825	0.006-0.009-0.0118	ACM
K	Cast Iron	250HB	325-575-825	0.006-0.009-0.0118	ACK

Identification Details (Inch) Shank Type

WGX 4 2000 EW

1 Cutter Series 2 Insert Series 3 Diameter (2.000") 4 Endmill Type

Identification Details (Metric) Shank Type

WGX 13 032 EW

1 Cutter Series 2 Insert Size 3 Diameter (32mm) 4 Endmill Type

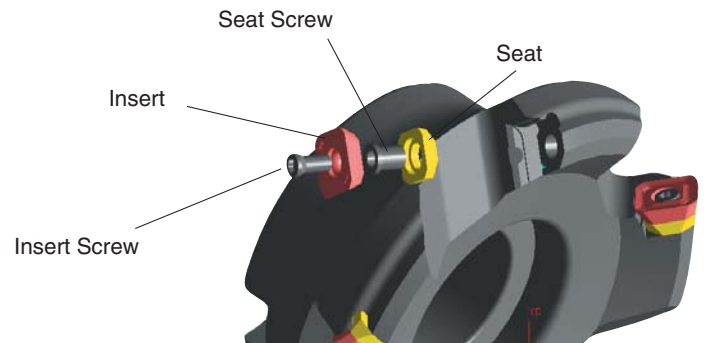

Sumitomo WGX and DGC Comparison

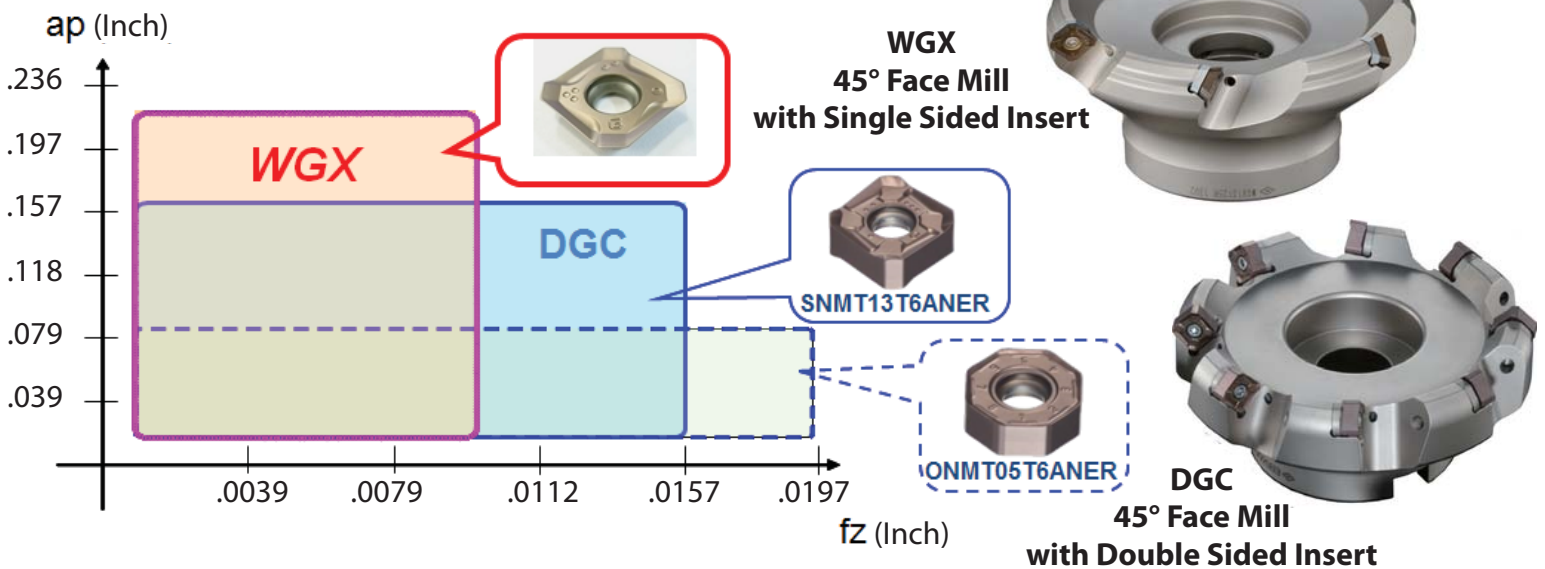

Needs	Surface finish	Cutting force	Efficiency	Strength	Chip emission	economic efficiency	general versatility
Recommend	WGX	WGX	DGC	DGC	WGX	DGC	WGX



SUMITOMO

CARBIDE - CBN - DIAMOND

Sumitomo Electric Carbide, Inc.

Headquarters

1001 Business Center Drive
Mount Prospect, IL 60056-2181
P.O. Box 545, Mt. Prospect, IL 60056-0545
Phone: (800) 950-5202
Phone: (847) 635-0044
Fax: (847) 635-7866
<http://www.sumicarbide.com>

Sumitomo Electric Tool Engineering Center

5637 S. Westridge Drive
New Berlin, WI 53151
Phone: (800) 950-5202

Cincinnati Branch

4450 Carver Woods Drive
Cincinnati, OH 45242-5545
Phone: (800) 879-1887
Phone: (513) 891-4000
Fax: (513) 794-2911

Torrance Branch

21221 South Western Avenue
Suite 200
Torrance, CA 90501
Phone: (800) 950-5202
Fax: (310) 782-0211

Detroit Branch

14496 Sheldon Road #230
Plymouth, MI 48170
Phone: (800) 239-5177
Phone: (734) 451-0200
Fax: (734) 451-5338

Huntsville Branch

5650 Sanderson Street NW
Suite J
Huntsville, AL 35805
Phone: (256) 895-2845
Fax: (256) 895-3150

Sumicarbide Canada, Inc.

2600 Skymark Avenue
Building 6, Suite 103
Mississauga, ON L4W 5B2
Canada
Phone: (905) 282-9986
Fax: (905) 282-9984



For more information log onto:
www.sumicarbide.com